

1 Introduction

The Air Mortar is a fast-acting pneumatic system, designed to provide a rapid discharge of inert gas when triggered by 12VDC input signal. The standard system vessel has a volume of 17.7 litres but can be supplied in other volumes, it can be operated at any pressure from 40 to 580psi (2.75 to 40bar).

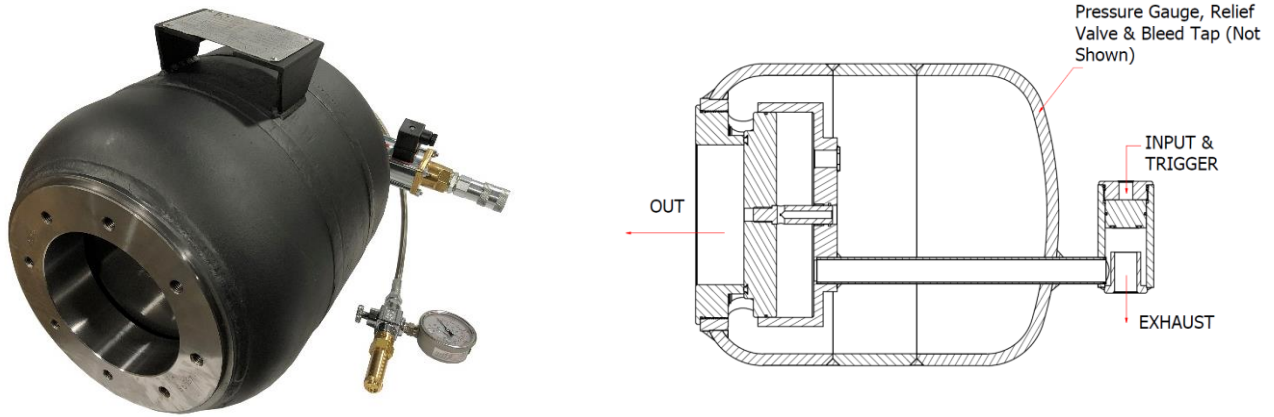

Figure 1 Air Mortar and Section through Air Chamber

2 Safety

Compressed gas equipment is dangerous when operated incorrectly. This System should only be used by competent persons, operated in accordance with local regulations for air equipment and with appropriate safety assessments. It is essential that the operator fully reads and understands these notes prior to operating the System. Once the System has been charged with Air it should be treated with the same caution as a Pyrotechnic Mortar Pot. The integrated Pressure Relief Valve is set during assembly by the supplier and must be used to prevent the system exceeding its rated pressure.

3 Operation

Figure 1 shows the section through the System identifying the direction of operation; the three stages of operation are illustrated in Figure 2.

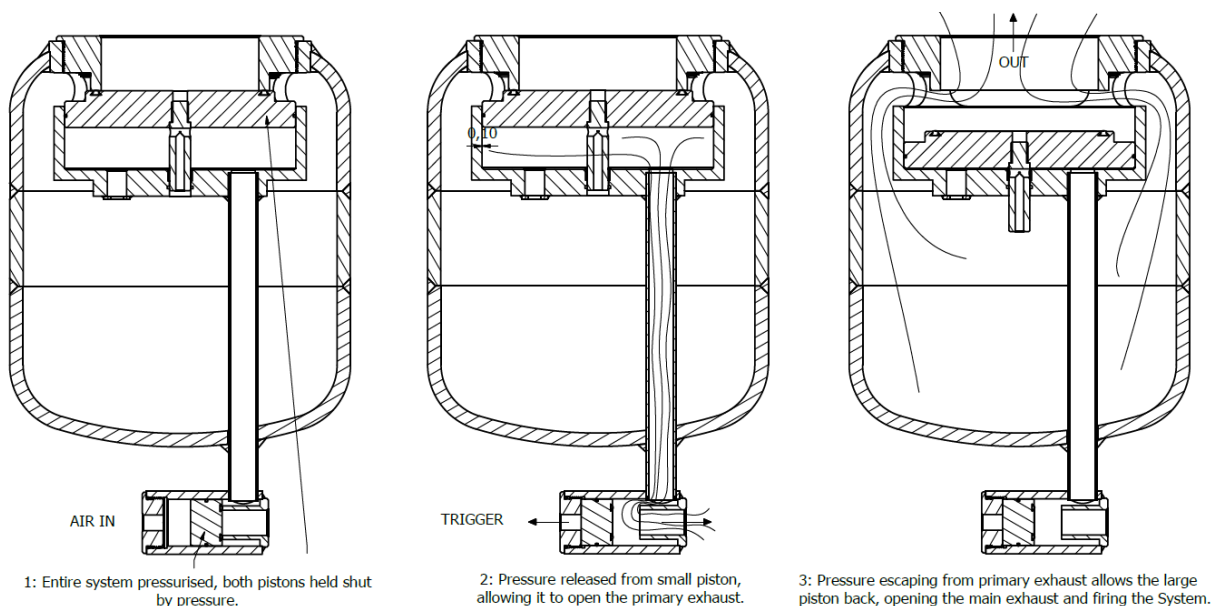

Figure 2 Cross section of the System in three phases of operation - illustrating the Operation

The System may be operated with a gas such as Nitrogen, CO₂ or Air. Exposure to very low temperatures, such as when used with CO₂, may cause the piston seal to harden. This may prevent complete sealing until the valve warms up. The System is supplied with a ½" Female Flat Face Quick Release Connector on the Air Inlet side; the User should choose an appropriate Air Supply and Regulator. Dependent on the effect, the Operator may set up a snoot which can be bolted directly to the output flange, an example is shown in Figure 3. The standard bolting pattern on the Output flange is also shown in Figure 3.

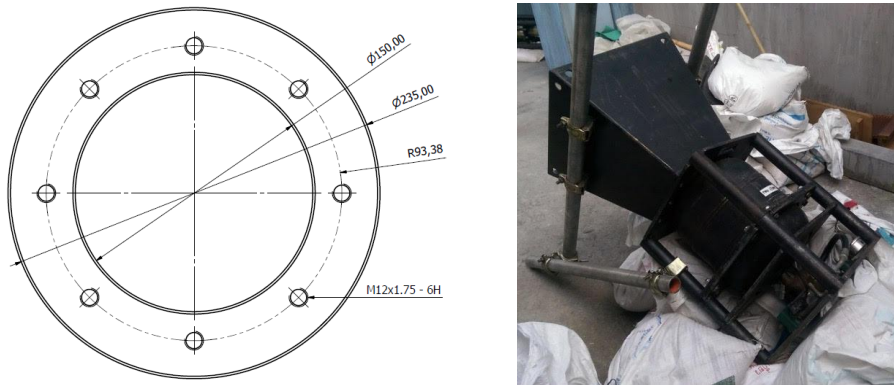

Figure 3 Output Interface and example of assembled with Snoot

The following guidelines should be used when operating the System:

1. Care should be taken to prevent debris or contamination from entering the system past the Main & Trigger Pistons when it is loaded as this may prevent the System from sealing properly or may cause it to jam. Before loading the snoot, the System may be pre-charged with a low pressure (less than 1 bar) which is sufficient to seal the main piston and prevent debris passing into the vessel past the main piston. Only when the snoot is loaded and prepared for the effect should the System be charged to an appropriate pressure;
2. Once charged the System is operated by triggering the Solenoid releasing the Trigger Piston, the Wallbanger is supplied fitted with a 12VDC solenoid valve for this purpose. To operate at different voltages, the solenoid coil can be changed. Even though the System is fitted with one-way valves it is good practice to leave pressure connected to the Input to prevent loss of pressure on the Trigger Piston.

If it is necessary to release the pressure from the System without firing, the correct process must be followed to allow for the safe isolation of the System, the method is listed below. The Pressure Gauge, Manual Bleed Tap and Pressure Relief Valve are shown in Figure 6 (Appendix), the User should make themselves familiar with these parts and their operation prior to using the System.

1. Isolate the Air Supply;
2. Manually release the Bleed Tap on the bleed down circuit, allowing air to be bled down from the Vessel. The discharge can be monitored by noting the reducing vessel pressure on the Pressure Gauge and also with the noise generated by the escaping air;
3. The danger area should only be entered once the discharge is complete and the Air Supply isolated.

The System must be charged to remain within the operating pressure range using the selected Air Supply and Regulator. In the undesired event that the System is set to be charged beyond the maximum operating pressure the Vessel will discharge automatically through the pre-set Pressure Relief Valve. The Pressure Relief Valve is not a control valve and must not be relied upon to regulate the operating pressure.

4 Inspection, Maintenance and Spare Parts

This System should only be operated by persons competent in the use of Compressed gas equipment and inspected in accordance with local regulations necessary for Air Equipment. The CE plate, showing the build and test details, must not be removed from the System. At all times it is important to ensure that that the System is discharged and isolated from an Air Supply before any maintenance or servicing.

The seals on the Main and Trigger Pistons must be kept clean to ensure the system does not leak and care should be taken to prevent debris or contamination from entering the system. Prior to use it is recommended that the system is charged to a low pressure and checked for air leakage past the pistons. The Main Piston seal can be cleaned without dismantling the System whilst the Piston is in the return position (Stage 3 in Figure 2). To gain access to the Trigger Piston for cleaning the Trigger Plug must be removed. It is important that the Trigger Piston does not leak as when the System is charged with air, any leakage past this piston may trigger the System. If either piston is found to leak following cleaning of the System, they should be replaced by manufacturer original parts (Table 1).

The System is designed to be durable when handled and stored in an appropriate manner. The System should always be cleaned and dried after use and stored in a dry environment to ensure water does not condense in the System. If the System suffers from leakage it can be partly dis-assembled and serviced; once dis-assembled the O-rings, Piston Seals and mating faces should be cleaned before being lightly oiled and re-assembled. If any of the parts show signs of damage these should be replaced using the parts identified in Table 1 (shown in the Appendix), these parts can be ordered direct.

Table 1 Spare Parts List

ITEM	QTY	DESCRIPTION	PART NUMBER
1	1	Exhaust Flange.	EH17001D001
2	2	Main Piston and Exhaust Flange O-Rings.	Polymax 210x2.5N70
4	1	Main Piston.	EH17001D007
5	1	Guide Pin.	EH17001D002
-	1	Guide Pin O-Ring	Polymax 19.8 x 2.4N70
6	1	PTFE Coated bush, 20mmID, 23mm OD, 10mm high.	DU2010
7	1	Vessel Weldment with Cylinder (EH17001D0008).	Welded Vessel Assembly
8	1	Weldment of Trigger Exhaust (EH17001D0005) & Trigger Tube (EH17001D0004) onto Welded Vessel Assembly.	Trigger Weldment Assembly
10	1	Trigger Piston.	EH17001D006
11	2	Trigger Piston and Plug O Rings.	Polymax 40x2.5N70
12	1	Trigger Plug.	EH17001D003
13	1	¼" m/m (t/p) adaptor, 500mm braided PTFE Hose with ¼" female, ¼" m/m with 1x ¼" dowty Seal, ¼" 3way Bleed Block, ¼" 40 bar Pressure Relief Valve with ¼" dowty seal. ¼" 0-1000psi Pressure Gauge.	Custom Hose Wall-Banger kit - Pressure Gauge & Bleed Down Tail
14	1	3/8"x ½" m/m adaptor with ½" and 3/8" dowty seals, 40bar 12VDC Co-Ax Solenoid, ½" x ½" m/m adaptor with 2x ½" dowty seals, ½" 100bar pneumatic Check Valve, ½" m/m adaptor with 2x ½" dowty seals, ½" Flat Face Female Connector.	Custom Hose Wall-Banger kit - Air Inlet and Trigger

15	1	Vessel and Trigger Piston one-way valves VU1120 14X.	Custom Hose Wall-Banger kit - One Way Valves
----	---	--	--

5 Further information

5.1 Updates to the User Manual

Prior to operation the User should check the Event Horizon website for any updates to the User Manual and any product changes: http://www.precisionenergetics.co.uk/Docs/EH17001R001_User_Manual.pdf

5.2 Contact Details

For additional information or replacement parts please contact:

1. Event Horizon on +44 (0)1458 210 280; info@precisionenergetics.co.uk; or by post to 'The Old Brewery, Stagman Lane, Ashcott, Somerset, TA7 9QW. UK.' <http://www.precisionenergetics.co.uk/>
2. Custom Hose & Fittings on +44 (0)1923 225534; enquiries@customhose.co.uk; or by post 'Custom Hose, 194 Queens Road, Watford, Hertfordshire, WD17 2NT. UK.' <http://www.customhose-catalogue.co.uk/>

6 Appendix

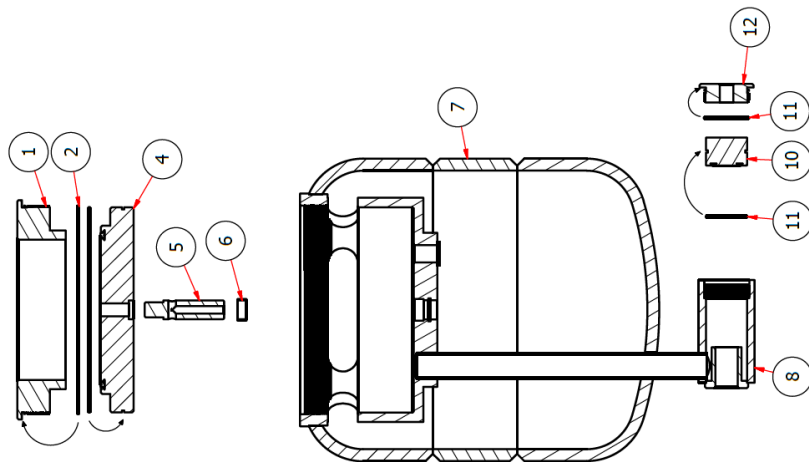

Figure 4 Section through Wallbanger - Table 1 Parts identified

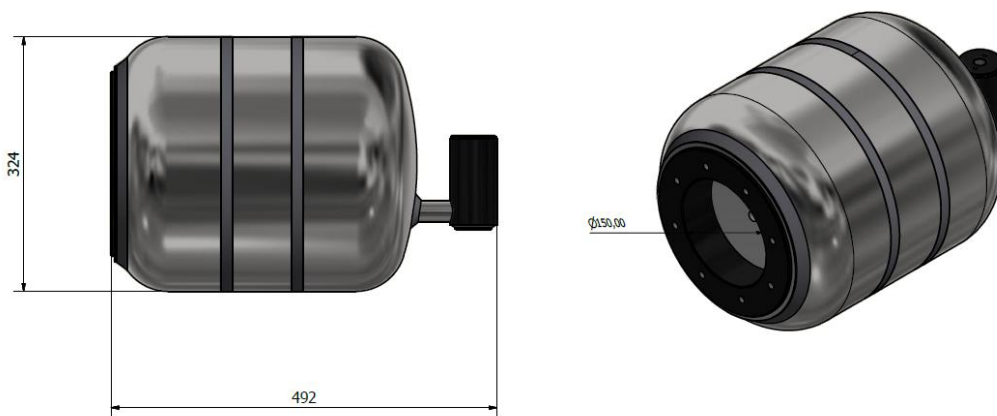

Figure 5 Overview of Wallbanger

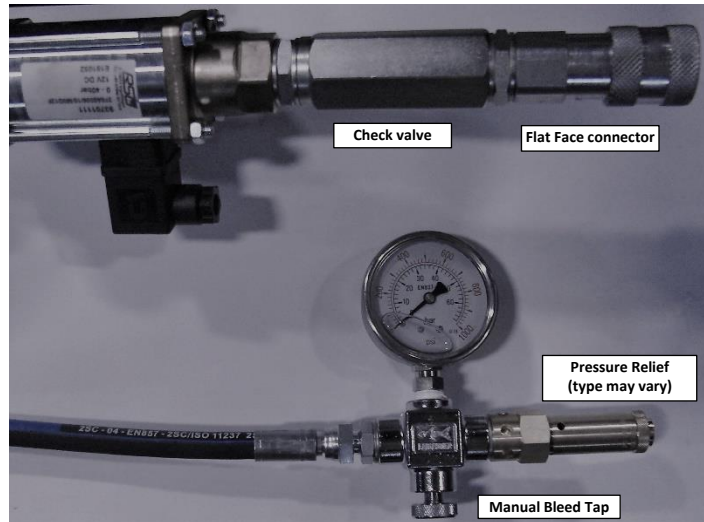

Figure 6 Detail showing: Flat Face, Check Valve & Pressure Gauge, Pressure Relief Valve and Bleed Tap